



**MODEL** KAWASAKI Z 650 / NINJA 650

**YEAR** 2017 -->

**LINE** FULL SYSTEM

**MUFFLER** DELTA RACE

**SCHEMATIC**

**ELENCO PARTI / PARTS LIST**

| #  | QTÀ / QTY | DESCRIZIONE / DESCRIPTION                           | CODICE / CODE |
|----|-----------|---|---------------|
| 1  | 1         | DB killer / DB killer                               | 50.DK.119.0   |
| 2  | 1         | Silenziatore / Muffler                              | DELTA RACE    |
| 3  | 1         | Staffa / Bracket                                    | 50.SS.1039.0  |
| 4  | 2         | Rondella di sicurezza / Safety washer               | 50.73.604.1   |
| 5  | 2         | Vite M8 x 16 / Screw M8 x 16                        | 50.73.098.1   |
| 6  | 2         | Boccola / Bush                                      | 50.73.381.1   |
| 7  | 1         | Silentblock / Silentblock                           | 50.73.380.1   |
| 8  | 1         | Rondella in alluminio nera / Black aluminium washer | 50.73.221.1   |
| 9  | 1         | Vite M8x45 / Screw M8x45                            | 50.73.602.1   |
| 10 | 1         | Db Killer / DB killer                               | 50.DK.081.0   |
| 11 | 5         | Dado M8 flangiato / Flanged nut M8                  | 50.73.393.1   |
| 12 | 1         | Collettore #1 / Down pipe #1                        | 9773K044S2A   |
| 13 | 1         | Collettore #2 / Down pipe #2                        | 9773K044S2B   |
| 14 | 1         | Tubo di raccordo 2-1 / Link pipe 2-1                | 9773K044S2C   |
| 15 | 1         | Molla lunga / Long spring                           | 50.71.080.1   |
| 16 | 2         | Molla media / Mid-size spring                       | 50.73.359.1   |
| 17 | 3         | Tubo in gomma per molla / Rubber pipe for spring    | 50.73.210.1   |

**Catalytic Converter**  
Cod. ACC.044.A1  
*Optional for K.044.LDRX - K.044.LDRB*  
*Included in K.044.KDRX - K.044.KDRB*

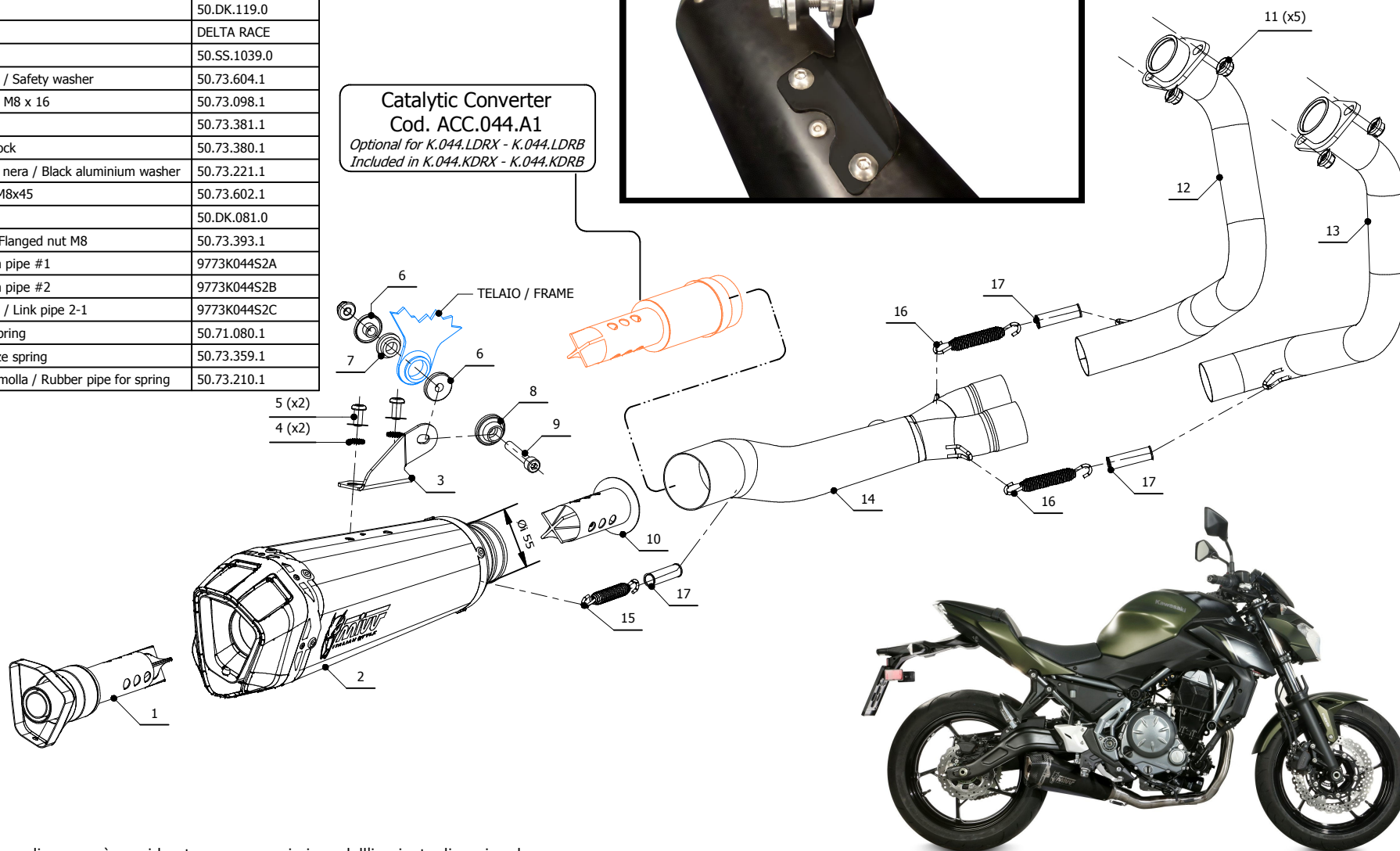
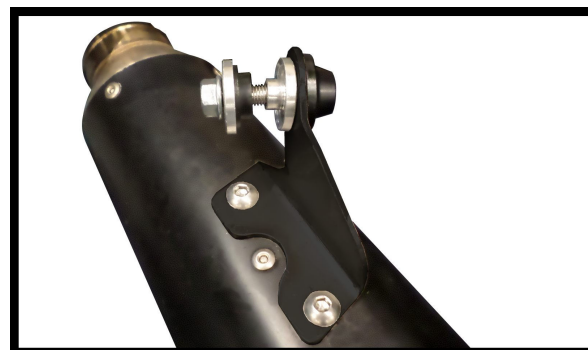

**ATTENZIONE:** La rimozione del riduttore di rumore è considerata una manomissione dell'impianto di scarico che comporta la perdita dell'omologazione per utilizzo stradale e della garanzia prodotto. In caso di rimozione del riduttore di rumore l'impianto di scarico è in configurazione "racing" e può essere utilizzato solo in pista.

**WARNING:** Removal of the noise reducer is considered a tampering of the exhaust system which entails the loss of both the type approval for road use and the product warranty. In case of removal of the noise reducer the exhaust system is in "racing" configuration and can be only used on track.

**APPLICAZIONI / APPLICATIONS**

| CODICE / CODE            | SILENZIATORE / MUFFLER  | TUBO / PIPE      | NOTE                                |
|--------------------------|---|------------------|-------------------------------------|
| K.044.LDRX<br>K.044.LDRB | INOX (COPPA CARBONIO) / ST. STEEL (CARBON CAP)<br>STEEL BLACK | INOX / ST. STEEL | CATALYTIC CONVERTER<br>NOT INCLUDED |
| K.044.KDRX<br>K.044.KDRB | INOX (COPPA CARBONIO) / ST. STEEL (CARBON CAP)<br>STEEL BLACK | INOX / ST. STEEL | CATALYTIC CONVERTER<br>INCLUDED     |